

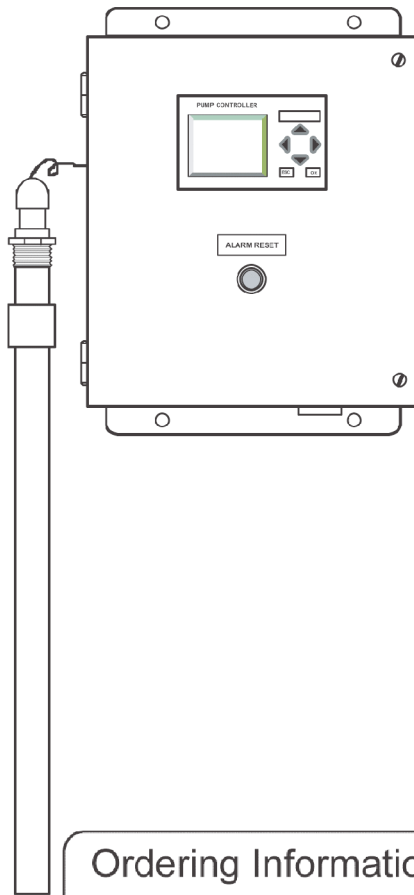

LEVEL MONITOR

LM

The Newest Design in State of the Art Technology, NWTC'S Latest Hydrostatic Level Probe and Monitor for Liquid Level Monitoring and Remote Fuel Fill Alarm.



Ordering Information

LM — 120
| |
Level Voltage
Monitor

Northwest Tech-Con System's Level Monitor is specifically designed to monitor and measure levels of diesel, water or non-corrosive chemical in tanks. The controller employs an embedded microcomputer and a hydrostatic float-less liquid level transducer to continuously monitor liquid levels. Users can change both the level and the alarm status at the data terminal screen.

FEATURES:

- Float less hydrostatic technology
- Low voltage analog signal
- Probe malfunction alarm
- Field programmable alarm status
- Measures up to 10' of liquid
- LCD screen with text to indicate levels
- Levels measured in cm or inches
- Visual and audible alarm
- Alarm silence switch
- Remote alarm dry contact
- SCADA and remote monitor (optional)
- UL approved



LEVEL MONITOR INSTALLATION

LM

TYPICAL INSTALLATION

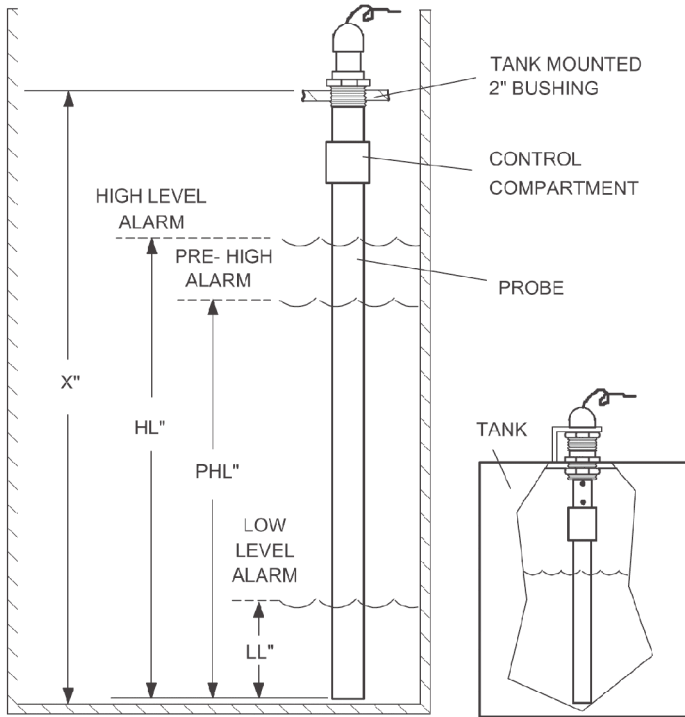

LEVEL MONITOR PANEL

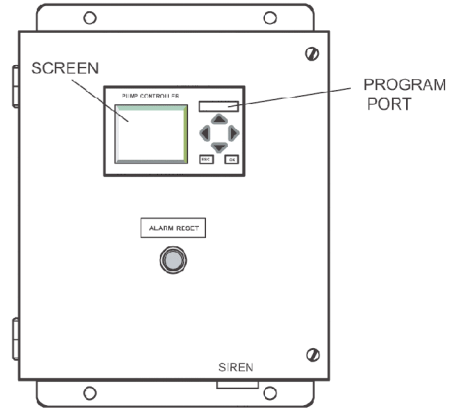

LEVEL MONITOR MODEL:

LM - /
OPTION (BY LETTER)
 TANK DEPTH IN INCHES

OPTION:

- A — CEMA OR NEMA 4 OUTDOOR
- B — CEMA OR NEMA 1 INDOOR
- C — ALARM STROBE LIGHT
- D — 90 db SIREN

PANEL SIZE:

- 12" X 12" X 8" NEMA 1
- 12" X 10" X 5" NEMA 4

PROBE MODEL: HPP -
TANK DEPTH IN INCHES

TEXT MESSAGES



NOTE: +00123 — CURRENT LEVEL HEIGHT (inches)
 @ XXX inch — AT LEVEL HEIGHT (inches) PROVIDED BY CUSTOMER