



SIMPLEX COMPRESSOR CONTROL PANEL **S-CCP**

**An Innovative Simplex Air Pressure Controller for:
 Residential, Commercial, and Municipal Applications. Operated by an Air Pressure Switch.**

120 OR 240 VOLT - SINGLE PHASE FROM 0.3 TO 1.5 HP

208, 480 OR 575 VOLT - 3 PHASE FROM 0.5 TO 50 HP



FEATURES:

- Modular circuit board
- Minimum RUN time
- Hand-off auto switch
- LED test / alarm silence / systems test push button
- Motor RUN indicator
- Power ON indicator
- Pressure ON indicator
- Low pressure alarm (audible and visual)
- Motor contactor and circuit protector
- Remote alarm (12VDC output)
- Easy troubleshooting and maintenance
- UL approved

Northwest Tech-Con System's S-CCP compressor control panel is a high quality simplex control system designed to maintain air pressure in a variety of compressor systems. NWTC controller is built for use with a complete line of compressors to provide maximum protection and efficiency for all models. A low voltage control module is used to operate the starting and stopping of the compressor with one compressor operating to handle normal pressure. A built-in alarm will sound when the air pressure is at high levels.

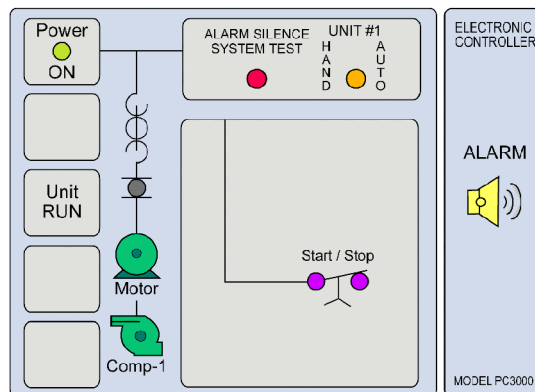

Ordering Information

S-CCP — 120 — A B E
 | | |
 Simplex Voltage Options
 Compressor by
 Control Panel Letter